

FIS

FINISHES & INTERIORS SECTOR



SITE GUIDE **PARTITIONING**



FIS Site Guide for Partitioning

Contents:

Introduction	2
FIS	2
Environmental Conditions	3
Materials	4
Deliveries; Handling; Storage	
Installation	5
Special considerations; Acoustics; Fire; Setting out; Perimeter fixings; Intermediate, vertical and horizontal members; Infill panels, cladding and trims; Door sets; Door frames; Doors – hanging; Glazing – general; Safety glazing requirements; Manifestation; Fire safety; Types of glass; Fire resistant glazing; Fixing; Scribing and cutting; Cover trims; Skirtings; Fixtures and fittings; Decorations and finishes; Wallcoverings	
Health and Safety	14
The Health and Safety at Work Act; The Construction (Design and Management) Regulations 2015; Site safety rules	
Site Clearance	16
Completion	16
Operation and Maintenance (O&M) Manuals; Maintenance	
References	17
Glossary of terms used in partitioning; List of standards and codes of practices, and other useful references.	

Site Guide for Partitioning

Introduction

The present generation of partitioning systems embraces a vast range of constructions and materials that provide maximum flexibility for the architect, interior designer and facilities manager. The versatility of the range is such that whether the requirement is for a fixed or relocatable system for simple space division, the accommodation of deflection head details or high performance in respect of fire resistance or sound insulation, there are many choices available to provide a pleasant and efficient working environment. The extensive portfolio of partition designs is complemented by a wide range of board and panel finishes, glazing options, doors, associated ironmongery and decorative wallcoverings.

The range of partitions installed by FIS members is wide and diverse. No attempt has been made, therefore, in this Site Guide for Partitioning to define specific procedures for installing individual proprietary partition systems where the directions of the manufacturer or supplier should always be followed. The *FIS Best Practice Guide for the Installation of Partitioning* can also be a useful reference point. However, the recommendations set out in this guide are applicable to most types of installation. To enable the client or building owner to obtain the benefit of optimum performance, it is necessary for the partitions to be installed not only correctly but also in the right environmental conditions. All personnel associated with their installation should be aware of what is deemed to be good practice in relation to health and safety, storage, handling and sequencing with other trades, as well as fixing. The aim is for this Site Guide for Partitioning to be useful to all members of the construction team.

The FIS recommends that its contractor members are used to install partitioning. A categorised national list of members is available on the FIS website at www.thefis.org

This site guide is not intended as a definitive technical manual, but rather an aide-mémoire and guide that will benefit main contractors, site managers/supervisors, designers, engineers and others involved with the building process. Additionally, it will help the reader understand the requirements of the specialist contractor if he is to fully function as a full member of the project team.

No specific reference has been made in the general text to movable, sliding and folding partitions which range from simple folding screens to custom-built wall systems with sophisticated tracking mechanisms. Nevertheless, most of the advice in the various sections of the guide will be relevant to their installation. Advice on the integration of movable walls into existing or planned structures can be obtained from FIS member companies specialising in these forms of construction. See the FIS website at www.thefis.org for details.

Finishes and Interiors Sector (FIS)

FIS speaks with one strong voice for the finishes and interiors sector. We work on behalf of our membership to raise awareness and increase the influence of the sector. We help members to make the most of opportunities through advice, training, technical support and dialogue with government and other bodies.

Our growing influence is based on the support we give to members, our ability to share knowledge for and about the sector, our determination to drive standards high and to encourage a sense of pride in the quality of our members' work.

FIS represents a growing sector, addressing key issues that affect our specialist members but also, more broadly, the construction industry and the UK economy. We aim to equip member companies to meet client needs more effectively, to make sure the sector has enough people with the right skills working to high technical standards, and to imbed a culture of quality and sustainable development. We focus on innovation because that creates a better tomorrow, but we are rigorous about health and safety because that affects the way we work today.

To achieve its overall objective of providing clients with the quality installations to which they aspire, the FIS requires the standards, materials, service and workmanship of its members to be of a very high order.

Environmental Conditions

The environmental conditions within a building under construction may be quite different from those that prevail in one that is completed and which may have been previously occupied or is currently in use. The conditions in a building under construction will vary considerably depending upon its state of completion, time of the year, the weather and the extent to which wet trades are involved.

The following conditions, therefore, are considered essential for the correct installation of partitions and associated linings.

- The building should be closed and weather tight.
- All wet trades should have completed their work and the areas to be partitioned should be sufficiently dry.
- The building should be in a proper condition with regard to cleanliness, temperature and humidity. The temperature and humidity should be maintained at levels similar to those that will prevail when the building is occupied.
- Clear access for vehicles should be available to facilitate unloading of materials.
- Clear gangways and access to lifts and staircases should be available. Difficulty of access can lead to damage of materials that in turn may reflect in the finished work. To prevent damage where access areas are unavoidably limited, suitable protection for finished and existing works should be made.
- To minimise additional handling, clear storage zones should be available adjacent to working areas; different types of boards/panels should be clearly identified and stored separately. Where appropriate, additional protection against damage should be provided. Sufficient space should be allowed to avoid exceeding weight loading of the floor area.
- To comply with the Health and Safety at Work Act, all electrically powered tools require a 110-volt supply.
- Adequate lighting should be provided to facilitate the production of a good standard of finish. The intensity and angle of lighting should be similar to that under which the final inspection will be made.

See also the FIS Health and Safety Handbook.

Materials

The design requirements of modern partitioning systems and associated elements involve a wide range of materials and components. It is important to ensure that they are properly transported, handled, stored and protected. Damage in transit or from poor storage and handling may result in unnecessary making-good and generate waste. It may also adversely affect the quality of the finished work. Specific information on the use of glass in glazed partitioning is referenced to in the FIS Site Guide for Glazed Partitions.

Deliveries

A point of delivery should be selected which is acceptable to the supplier and all other parties on site. It should cause minimum disruption while permitting maximum access and safe handling to the installation area. At the selected location, delivery tickets and certificates should be checked against specification and the condition of materials and components determined. In accordance with agreed procedures, shortages or damage should be reported immediately to the supplier.

The concentrated stacking of large quantities of materials on site may create a weight problem. Whenever possible, therefore, a pre-delivery survey should be carried out to establish whether or not the design floor loadings of the building or platforms are sufficient to take the weight and to determine if even distribution of the load over the floor area is required.

Handling

Care should be exercised in the handling of all materials and particular consideration should be given to the following:

- When slings are used for lifting, boards and panels should be stacked on a clean and dry platform and they should not overhang. To avoid damage, slings should be kept away from the board or panel edges by the use of spreaders and, where appropriate, side protection should be provided.
- When boards or panels are transported by dumper, crane or forklift truck, a supporting platform of suitable size should be used.
- When plasterboards or similar products are manually off-loaded or stacked, they should be carried on edge, two men to a board. Boards should not be carried with the surfaces horizontal as this imposes an undesirable strain on the core. When a board is handled, the long edge should be placed down before it is turned horizontally. Boards should not be dragged over each other as this can scuff the surface.
- Specialised equipment should be used for unloading and transporting glass to the installation areas. The recipient therefore should ensure that he is appropriately equipped to unload and subsequently handle consignments safely.
- The edges and corners of glass are vulnerable during handling (as well as in storage and installation); particular care should be taken, therefore, and protection provided to prevent damage that may cause subsequent failure.
- To prevent personal injury, operatives should wear suitable protective clothing including gloves and use proper handling equipment.

The handling of materials is an important part of site operations, proper attention to which will impact favourably on the quality of the finished work.

See also the Health and Safety section and FIS Health and Safety Handbook.

Storage

Many partitioning products are supplied in their finished state and, in addition to careful handling, should be stored in a clean and dry location, protected from accidental damage and inclement weather.

Pre-finished metal and timber partition modules, including doors, are normally supplied with suitable protection. They should always be stored under cover, stacked vertically or horizontally on raised support structures. Care should be taken during handling and storing on site to avoid damage and distortion. Lengths of aluminum, steel, plastics or timber components should be laid flat.

Materials and products such as plasterboard, timber, doors and laminates may be adversely affected by changes in temperature and humidity (see Environmental Conditions).

When storing glass on site particular attention should be paid to the following:

- Glass should be stored on its edge on raised support structures (A frame / stillage); whether it is the short or long edge will depend on size, substance and availability of space, etc.
- The angle of inclination or lean of the glass should be from three to six degrees from the vertical on static racks with sufficient lateral support to prevent bowing. An angle greater than six degrees will tend to put additional load on the back of the sheets and may cause breakage.
- Glass should be stored in clean, dry and well-ventilated conditions, out of direct sunlight and away from sources of heat. If moisture or condensation is apparent between panes of stacked glass, the panes should be separated immediately and dried thoroughly; otherwise they may stick together or be stained permanently.
- Glass should not be stored in contact with any substance that is harder than itself, i.e. concrete, stone or ferrous metals. To minimise further the risk of damage or breakage, all support structures should be clad with timber, felt or other relatively soft materials.

All materials and components should be stored in accordance with the recommendations of the manufacturer or supplier.

See also the Health and Safety section and FIS Health and Safety Handbook.

Installation

Before commencing any installation, site dimensions should be taken and where appropriate compared with architects drawings; discrepancies or problems should be discussed with and approved by the relevant authority. If necessary an official instruction or variation order should be sought before proceeding.

It is also important at this stage to clearly establish the difference between 'relocatable' and 'demountable' partitions. A relocatable or reusable partition system can be removed and relocated without substantial repair (using a minimum of 80% of original components). It should be capable of reinstallation within a tolerance of plus or minus 10mm of the original installed height. Demountable partitions cannot be taken down without damaging or destroying some or all of the components.

Special considerations

Partitions that are fixed to suspended ceilings may require special provisions in the ceiling construction or have appropriate supports fixed along the line of the partition between the ceiling grid and the structural soffit. Care should be taken to ensure that the head fixing of the partition does not impair the stability of either the partition or the ceiling it is fixed to.

In a similar way, partitions installed on raised access floors or platforms should be located at the positions within maximum loadings recommended by the floor system supplier or have additional supports included in the design.

When a partition is required to provide fire resistance, voids above or below the partition, eg ceiling or platform floor voids, may require to be sub-divided with cavity barriers in the plane of the partition. Fire stopping will also be required to seal any gaps between fire resisting partitions and other elements, such as trunking, pipes, etc.

Acoustics

Where a partition is required to provide sound insulation, the acoustic characteristics of the floor, ceiling and surrounding construction should be considered. In order to achieve good acoustic performance the partition should ideally be constructed between the floor and the structural soffit. If built on top of a raised floor and beneath a suspended ceiling then a sound insulation barrier will need to be installed in both plenums.

Fire

Where a partition is required to provide fire protection, voids above or below the partition may need to be sub-divided with cavity barriers in the plane of the partition. Fire seals will also be required where openings are made within the partition for trunking and cabling etc.

Setting out

Partitions should be erected in accordance with layout drawings and/or other instructions from agreed identifiable data and reference points, allowing for permitted deviations from nominal panel sizes and dimensional variations of finished ceilings, floors, walls etc.

Perimeter fixings

- When appropriate fire and acoustic seals/sealants should be fitted during the installation of the perimeter sections in continuous strip leaving no gaps.
- Abutments, junction posts, head and floor tracks should be fixed in line and plumb in both vertical planes in accordance with manufacturer instructions.

Special procedures may be appropriate for proprietary metal monobloc, bibloc and storage wall systems that have integral ceiling channels and special modules for junctions to wall, columns and mullions.

The '*FIS Best Practice Guide for the selection and installation of top fixings for suspended ceilings*' has useful information on perimeter fixings.

Intermediate, vertical and horizontal members

- All vertical sections should be fixed plumb in both planes and unless curved, in line with each other. Special attention should be paid to the fixing of verticals adjacent to door frames.
- Horizontal members, eg transoms or crash rails, should be set out level and in line with each other, after ensuring prior to fixing that each member is cut square.

Infill panels, cladding and trims

Infill and cladding panels should be free from bowing, undulations or other distortions with joints accurately aligned with no lipping.

Intermediate joints in exposed perimeter sections and trims should be minimised by using the full range of section lengths available. Joint compounds should be those approved by the manufacturer.

Certain types of panels may be prone to movement in areas of extreme temperature or moisture content. In these circumstances, appropriate allowances should be made or special fixing details incorporated.

Door sets

As partition systems are used in a multitude of applications, the types of door and frames available incorporate a wide variety of core materials and performance characteristics. Where acoustic or fire performance is required doors, frames should be treated as sets and fitted strictly in accordance with manufacturer instructions and test certificates.

Fire rated door sets in particular must be fitted with correctly specified components. Substituted or modified items may adversely affect performance or negate certification.

There are four main types of fire resistant door sets:

- Timber doors in timber frames
- Timber doors in metal frames
- Metal doors in metal frames
- Glass doors in metal frames
- Glass doors in frameless glass partitions

All of the above behave in different ways in real fire situations and consequently the installation requirements for one type will not automatically apply to another. Approved methods of build should be used at all times.

Timber and metal doors may include vision panels but the size of the glazed aperture should not exceed that recommended by the manufacturer. The maximum permissible size varies depending on the performance level and the type of glass specified.

Door frames

Posts should be fixed plumb, parallel and straight with the transom level set out to suit the height of the door, taking into account the level of the floor. For partitions with transoms to suit standard height doors, it is essential to work from the lowest point of the floor at the frame location to avoid unnecessary gaps beneath

the door. Mitres on aluminium or steel frames should be secured using the cleats provided or screw fixed where appropriate. Mitres or square joints on mortice and tenon timber frames should be tight and flush.

Doors – hanging

To operate effectively and with limited maintenance throughout the life of the partition, doors need to be correctly installed at the outset.

- Doors should be hung with the gaps between the door and the doorframe being consistent. Best practice would be for a 3mm gap at the top and sides of the door, and 3 to 5mm at the bottom of the door, depending on the type and thickness of the floorcovering and the underlying level of the floor. *BS 1245* offers guidance on the installation of doors.
- Doors intended for painting should receive an undercoat immediately after delivery followed by a further coat as soon as possible and not later than seven days after.
- All sealed door edges that are reworked should be sanded and resealed. Reworked unsealed edges should be sanded.
- Butt hinges, locks and latches should be cut flush into the edge of the door giving the mortice a snug fit or positioned to suit manufacturer instructions.
- Acoustic and fire rated door assemblies should be fitted with the appropriate intumescent strip/cold smoke/acoustic seals to achieve the required performance levels.
- Closing devices should be fitted to all fire rated door assemblies.
- All screws in hinges, locks, latches and closers should finish flush with the surface.
- Keys left in doors may be lost, be stolen or lead to damage. They should be labelled and handed to the appropriate authority and a receipt obtained.
- It is important that gaps between the door and the door frame are consistent. Best practice would be for a 3mm gap at the top and sides of the door and 3-5mm at the bottom of the door depending on the type and thickness of the floor covering and the underlying level of the floor. *BS 1245* offers guidance on the installation of doors. Particular care should be taken when installing drop-down smoke/acoustic seals.

Glazing – general

The regulations covering the use of glass in partitions are comprehensive and specifically detail the performance requirements in relation to fire, impact, and visibility in both partitions and doors. The glass type and finish specified should therefore be capable of complying with the regulations in all respects. For more detailed information see the *FIS Site Guide for Glazed Partitions*.

Safety glazing requirements

The following documents apply to safety in glazing:

- BS 6262: Glazing for Buildings 2005.
- Building Regulations 2000: Approved Document N.
- The Building (Scotland) Regulations 2004: Technical Handbook 4: Section 8.
- The Building Regulations (Northern Ireland) 2000: Technical Booklet V.

BS 6262, is a national standard applicable to both new and replacement glazing that includes information regarding materials and required performance levels etc. The other documents provide information on

building work that is subject to formal approval and provide guidance on how compliance with the regulations may be achieved.

All the regulations require that the risk of injury should be minimised in areas where there may be accidental human impact with glazing. This should either be by:

- Fitting glazing of a type, thickness and pane size that will be resistant to impact, which either does not break or breaks safely; or
- Providing protection in the form of guarding to vulnerable glazing.

Some glazed areas are more likely to be subject to human impact such as screens within 800mm of floor level, part of a door leaf or screens within 300mm of a door leaf and within 1.5m of floor level.

These must be designed for impact as described in BS 6262 Part 4: 2005. Safety glass should always be installed so that the Kite mark and/or logos are located in the same place on each pane for ease of inspection.

Parts 3 and 4 of Approved Document N refer to the requirements for the safe opening and closing of windows and safe access for cleaning windows.

Copies of the Building Regulation Documents are available online from the following websites:

- UK and Wales: www.planningportal.gov.uk/approveddocuments
- Scotland: www.sbsa.gov.uk
- Northern Ireland: www.buildingcontrol-ni.com

Manifestation

Window films can be applied to glass within partitions for a number of reasons:

- **Document N:** Manifestation is necessary in critical locations where people may not be aware of the presence of glazing and may collide with it. Where manifestation is necessary it may take the form of broken or solid lines, patterns or company logos at appropriate heights and intervals. The more recent Document M now takes preference of Document N and provides guidance on the type position and finish of manifestation.
- **Document M:** Access to and use of Buildings, which includes information on both doors and partitions. Compliance with Building Regulations (see section below)
- **Privacy:** Privacy within meeting rooms and offices can be achieved without loss of light or change of partition design.
- **Identity:** Company logos or room names can be included within window film designs to provide identity within the office environment.
- **Safety:** Non compliant glass can be upgraded to meet the requirements of BS 6206.
- **Blast film** – designed to be used on toughened glass to eliminate glass shards being scattered following an explosion.
- **Application method** – installation of manifestations should be carried out at the end of the project, when the site is clean and dust free. Glass should be cleaned thoroughly prior to application taking care not to scratch the glass.
- Glass is marked with a level line on the opposite side of the glass with a spirit level, chalk line or laser level, to ensure that the manifestation is straight and level once applied.

- Clean water and application solution are then used to apply the manifestation to the glass, taking care not to wet any carpeting. The manifestation should not overlap silicone joints or edges of glass.
- Once the graphics are dry and finished, any water marks should be cleaned off, Graphics should not then be cleaned again for 30 days.
- **Visual inspection** – of the graphics should be carried out from the side that the manifestation has been applied, from a distance of 2 metres.

For further information see the FIS Site Guide for Glazed Partitions.

Fire safety

The requirements for solid and glazed partitions within the UK are contained within the following documents:

- The Regulatory Reform (Fire Safety) Order 2005.
- The Building Regulations 2000: Approved Document B (Fire Safety) – Volume 2 – Buildings other than Dwellinghouses (2006 Edition).
- The Building (Scotland) Regulations 2004: Technical Handbook Section 2 – Fire.
- The Building Regulations (Northern Ireland) 2000: Technical Booklet E.

Partitions (including glazed partitions) that form compartment walls or escape routes must retain stability and provide insulation for specific periods of time. Glazed areas on escape routes below 1100mm from floor level must also provide the same levels of protection while still meeting the safety requirements previously described.

Glazed assemblies should be constructed using the same materials as those tested and installed using the methods contained within the manufacturers' method statement. Only manufacturer approved glass should be used within the partition and the area of glass should not exceed the maximum permissible. Substitution of materials or alteration of build methods may affect performance and/or negate certification.

Types of glass

Toughened glass is float glass that is heat treated (tempered) and is used as a safety glass. When broken it shatters into relatively small particles, however these may still be hazardous. All edgework, drilling or surface decoration must be carried out prior to the toughening process as the glass cannot be altered or reworked once treatment is completed.

Laminated glass is two or more sheets of float glass that are bonded together using a special interlayer and is used as a safety glass. If broken the pieces are retained by the interlayer and if properly supported will remain within the partition without shattering. Cut outs, notches and mitred edges should be carried out under workshop conditions, however unlike toughened glass, laminated glass can be reworked if necessary.

Wired glass is a product in which a steel wire mesh is sandwiched between two separate ribbons of semi-molten glass, and then passed through a pair of metal rollers which squeeze the sandwich of glass and wire together. It has an impact resistance similar to that of normal glass, but in case of breakage, the mesh retains the pieces of glass. This glass is not considered to be best practice in terms of office partitioning.

Switchable LCD privacy glass/film normally has a diffused white appearance which acts as a screen, but can be made transparent simply by passing an electric current through it. The liquid crystal film is sandwiched by two layers of conductive film, which is then laminated between two pieces of glass. Available in 10mm,

12mm, and 14mm thicknesses, the system is operated by electrical switch or remote control via a transformer and should be installed in accordance with *BS 7671 IEE Wiring Regulations 17th edition*.

See the *FIS Site Guide for Glazed Partitions* for more information.

Fire resistant glazing

The term fire resistant glazing describes not just the type of glass but the complete assembly comprising frame, method of frame fixing, glass and method of glazing.

Fire rated glasses may be wired, annealed, monolithic, laminated, pyroglass or be required to provide insulation. There are many variations from different manufacturers. Each type of glass reacts differently when subjected to fire, and methods of installation vary in order to achieve stated levels of performance. The importance of following manufacturers' approved methods of build and using approved materials cannot be overstated as poor handling, fitting and finishing may cause failure in the event of a fire.

Fixing

All horizontal and vertical glazing beads (metal, plastic or timber) should be cut and fitted in line with manufacturer instructions with bespoke installations conforming to standard practice. Beads, gaskets and sealants should be fitted and applied with care particularly in relation to fire and acoustic performance. To ensure correct positioning, beads should be marked prior to temporary removal for glazing.

Where silicone glazing systems are used, edge cover at the head and base of the partition should be a minimum of 12mm and the type and size of glass used should be appropriate for the partition height and within the limitations of the system.

Where dry joint trims are used, the adhesive strip inside the sections should be fitted firmly to the vertical edge of the glass panel. Where adhesive tape systems are specified, glass should be levelled with specialist equipment prior to the application of the tape. Where silicone joints are used, consistency should be maintained throughout and any silicone deposits on the face of the glass removed with a suitable solvent.

Gloves and other appropriate protection should be worn when handling or installing glass, (see site safety rules in the Health and Safety section of this guide, and the FIS Health and Safety Handbook).

Best practice in all partitioning situations would be to use safety glass to BS EN 12600 and BS 6262 at all times, with the Kite marks and/or logos located in the same consistent place on each pane, ideally in the bottom left or right hand corner, facing outwards from the partition face, to make inspection easier.

Further information on glass and glazing is contained in the FIS Fact File (in particular Information Sheets 'Glass and the Workplace' and 'Glass and Glazing'), in Glass and Glazing Federation (GGF), TRADA and FIRAS publications and in system manufacturers' literature. See also the *FIS Site Guide for Glazed Partitions*.

Scribing and cutting

Scribing is an essential part of site work, requiring careful attention. Areas that may require scribing include abutments, infill sections and obstacles at head and skirting level such as beams, skirting, ducting and pipework.

On large projects with multiple scribes, the use of a template is recommended for marking panels before cutting. Minor discrepancies should be filled using an appropriate caulk or mastic, removing the need for additional cover trims or plates.

Small scribes are best executed by using an adjustable multi-pin scribing tool where the pins self adjust to the exact shape required. The shape can then be transferred to the panel and a perfect cut achieved.

To obtain the best results when scribing metal faced panels, it is recommended that a master template and a metal cutting jigsaw or knibbler are used. Attention should be paid to the appearance and function of the finished work to ensure that the acoustic and/or fire performance of the partition is maintained around ducting and pipework etc. Approved sealants should be used where necessary.

Cover trims

Many trims are functional as well as decorative and should always be fixed in accordance with manufacturer's instructions. Failure to do so may adversely affect the partition's performance.

Skirtings

Installed in accordance with manufacturer instructions, skirting sections should have clean high quality cuts, whether square, mitred or scribed with no loose, buckled or overhanging sections.

Fixtures and fittings

Where special fixtures and fittings are required, the type of partition specified should be able to carry both the fixings and the finished load. Where heavy loads such as television screens, washbasins etc are to be fitted, supporting frame work such as fixing plates or plywood back panels should be incorporated within the core of the partition. Manufacturer's recommendations should be sought in respect of precise loading capacity and associated fixing details.

A wide range of fixings are available to attach objects to plasterboard partitions such as spring toggles, steel expanding and self drilling devices. Guidance on the fixings and their application is available from Construction Fixings Association www.fixingscfa.co.uk Detailed information should be obtained from suppliers.

The strongest and neatest installations are achieved by drilling neat holes. A screwdriver or similar tool should not be used to force a hole through the board as this will damage the back face of the board and weaken the fixing.

Some nylon and plastic cavity fixings are designed to expand simply by inserting the screws into the housing. The correct type of fixing should always be used and should not be over-tightened as this may damage the insert or the area surrounding it.

Decorations and finishes

Care should be taken to avoid damage to all partitioning elements when handling, storing and installing components, particularly pre-finished products. Where surface damage occurs, manufacturer's maintenance recommendations should be referred to before attempting repairs.

Once installed, pre-finished components located in vulnerable positions eg veneered panels, door sets, ironmongery, corner posts etc may need additional protection prior to practical completion.

The front of plasterboard panels (ie the face without overlapping paper) is suitable to receive most forms of decoration;

- Square edge panels are normally fitted with cover strips to hide the board joint with trims fitted after the chosen form of decoration has been applied.
- Bevelled edge panels usually arrive to site pre decorated, with the wall covering wrapped around the panel edge
- Tapered edge boards should have an appropriate joint tape or scrim applied to the board joint. The joint can then be finished with jointing material or alternatively the face of the partition can be skimmed or receive a coat of plaster.

Drywall partitions that are subjected to delays in decoration following the application of jointing material may be treated with a primer, reducing moisture absorption and the risk of discolouration. This also equalises suction, provides an even texture and allows easier removal of wallpaper and fabrics. The suitability of all finishing treatments should be checked against manufacturer's recommendations.

Where ceramic wall tiles are to be applied to the partition, board type and stud centres should match those recommended by the partition manufacturer.

Wallcoverings

It is recommended that, where possible, wallcoverings are applied to panels prior to fixing. Pre-decorated panels should be stored flat to avoid warping/bowing and kept in dry conditions in neat stacks. To protect the decorative face, panels should be stacked finished face to finished face and back to back. If the applied covering has been wrapped around the board edges, a packer strip should be inserted every fourth board to avoid bowing in the stack. The stack should not contain more than 50 N° 12.5mm plasterboards or 16 N° composite panels.

When applying coverings directly to finished walls, ensure that the substrate is clean, smooth and free from imperfections and where absorbent surfaces are involved that they have received an appropriate sealant. Non-absorbent surfaces should be rubbed down thoroughly to provide a key and then washed with a detergent solution, rinsed off with clean water and allowed to dry.

The correct sealed surface adhesive should be used and manufacturer's recommendations followed with care taken to ensure that:

- The site is heated to at least 12°C (55°F) with good ventilation.
- The make, colour, batch number and quantity of each roll are checked.
- Wallcoverings from different batches are not used on the same partition or wall area.
- Good lighting conditions prevail – at least to the standard to be used for final inspection.
- Attention is paid to the start and finishing points and the hanging sequence.
- The shelf life of the adhesive has not been exceeded.
- The adhesive has not been subject to low temperatures – if stored below freezing it may become unstable.
- The adhesive does not get on the face of the covering as complete removal may not be possible.

- Cuts are made with care to avoid damage to other surfaces.
- Only full width material is used and narrow widths above door frames should be avoided. Off-cuts and out of sequence drops should not be used to infill.
- Each drop is checked for shading as work proceeds.
- The top and bottom of each drop is allowed to settle for at least 15 minutes before trimming is carried out. Only sharp tools should be used and excess adhesive should be removed with a damp cloth.
- Edges of materials (particularly textiles) are not damaged by overworking or using a hard roller.

Health and Safety

The Health and Safety at Work Act

The Health and Safety at Work Act 1974 imposes a general duty on employers to ensure so far as is reasonably practicable the health, safety and welfare at work of all their employees. The Act also provides, without prejudice to the generality of their duties, a list of specific duties of employers in respect of their employees. Contractors should play their full part in overall safety onsite by adhering to the specific provisions and by making their site personnel aware of the need to conform to site safety rules at all times. Full co-operation should be sought from all other parties to the contract as far as site operations are concerned.

The specialist contractor and main contractor must provide a method statement and risk assessment of the work that has to be undertaken on each project. All members of the construction team have a duty of care to their site colleagues. Working to agreed programme's and to formalised method statements can contribute to site safety. Identifying hazards and assessing potential risks should cover the working environment, the work to be done, the tools and equipment to be used and the materials to be installed.

Guidance can be sought from the '*FIS Health and Safety Handbook*'.

The Health and Safety at Work Act 1974 also requires that materials and products are safe and without risk to health when properly used. However, when materials and products that are potentially harmful are used, it is imperative to adhere to the manufacturers' instructions and recommended safety precautions. The Control of Substances Hazardous to Health Regulations (COSHH) 2002 relate to these duties under the Health & Safety at Work Act and employers must meet their obligations in respect of this legislation.

The Construction (Design and Management) Regulations 2015

The CDM Regulations place duties on all those who contribute to health and safety on a construction project, including clients, designers, principal designers, principal contractors and contractors. They also require the development of the Construction Phase Health and Safety Plans and creation of the Health and Safety File.

The CDM Regulations apply to all Commercial and Domestic construction projects. In consequence, the contractor will be involved in projects that fall within scope, eg new build contracts, and refurbishment contracts.

Key points on the CDM Regulations 2015

A Client must appoint in writing a Principal Designer and Principal Contractor when there is more than 1 contractor on site.

A Construction Phase Plan is required for all Construction projects

projects are notifiable when;

- The construction work will last longer than 30 days and 20 people working simultaneously at the same time or last longer than 500 person days.

The aims of the CDM Regulations include the following:

- To ensure that all parties consider the hazards and risks associated with the work or location in advance.
- To encourage project planning i.e. the co-ordination of activities.
- To ensure that a written control document, the Construction Phase Health and Safety Plan, is developed.
- To ensure that future work and maintenance issues are considered.

If there is any doubt as to whether you don't understand your responsibilities or when your contract falls within the scope of these Regulations, the advice of a health and safety consultant should be sought.

The importance of compliance with these regulations cannot be overstated as the authorities are looking for a responsible approach to be taken by all those involved in any form of construction related activity.

Site safety rules

All employees should adhere to the following:

- Upon arrival on site they should report to the project manager, site agent or client contact and familiarise themselves with specific site safety and health regulations. They should also identify the nearest fire alarm point, fire exit, fire extinguisher, first aid box to their place of work.
- In general, main contractors will hold an induction session for all site operatives including supervisory staff to cover compliance with national insurance, CSCS cards and general site conditions.
- Health and safety together with signage will be covered at the induction meeting and whilst the main contractors provide site safety signage, at this point the subcontractors may be asked to provide specific special signage in their workplace for issues such as the use of hazardous substances or equipment.

They should also:

- Work in accordance with any agreed Safe System of Work or Method Statement.
- Acquaint themselves with the fire procedures for the site or building and observe the relevant rules.
- Obey all site instructions regarding the wearing of personal safety equipment such as hard hats, safety glasses, ear protection, footwear, etc.
- Know to whom all accidents are to be reported and the procedures to be followed.
- Know to whom all defects in plant and equipment must be reported.
- Keep all gangways, exits and work areas clean and tidy and ensure that fire exits and staircases are kept free from any materials or debris, especially in occupied premises.
- Maintain good housekeeping throughout all areas of work by never leaving floors wet, and lifting and clearing waste regularly and ensuring that recyclable waste materials are segregated and deposited in the relevant containers. Be aware that other site personnel may not be familiar with the working practices involved, for example, in the installation of partitions and/or suspended ceilings.
- Provide adequate protection and signs for the safety of others when their activities create a hazard.
- Never run, especially when on scaffolding.

- Obtain assistance when heavy items require to be lifted. Always bend knees and lift with a straight back.
- Follow correct hygiene and first aid procedures in the event of minor injuries. (Injection against Tetanus for site operatives is recommended.)
- Ensure that machine and hand tools are used correctly and that worn tools and equipment are replaced.
- Acquaint themselves with the safety rules regarding the use of special machines and, where appropriate, use guards; avoid wearing loose clothing near moving machinery and not wear ties and rings when using power tools or similar equipment. (It is inadvisable to use special power tools if working alone on site.)
- Refrain from interfering with or adapting any equipment or service without proper advice or permission.
- Refrain from nailing objects to ladders and steps and do not remove guard or kick rails on towers or scaffolding.
- Obey site instructions concerning mobile plant and never ride on open hoists.
- Ensure electrical equipment is properly connected. Safe working practices require the use of 110-volt power supply. Where practicable, electrical plant when not in use should be isolated.
- Ensure all precautionary measures advised by the manufacturers are taken when lasers are to be used.
- Ensure that if hazardous materials are identified during the course of the work, the site health and safety officer and the installer company is advised immediately.
- Wear safety glasses and gloves and other appropriate protection when handling glass, particularly annealed glass. Damaged glass should be broken into small pieces and placed into boxes or bins marked 'Danger - broken glass'; do not place into sacks or bags.

Site Clearance

All surfaces should be left in a clean condition. This includes cleaning and polishing all glass and aluminum sections. Particular care should be taken with double glazed sections.

All debris should be removed from the work area and routes to this point, including lifts and staircases. Protection covers and dustsheets should be removed and, where appropriate, carpets and floors cleaned. All areas should be left clean and tidy.

Completion

Before handover, all works should be checked to ensure that they have been executed and completed to specification, including agreed variations and additional items. Where appropriate, arrangements should be made to meet the client or his appointed representative to inspect the finished work and to agree handover.

Operation and maintenance (O&M) manuals

It is good practice, when work has been completed, to obtain signatures from the main contractor on a completion handover certificate, to avoid later disputes on any damage to the partitioning caused subsequently by others.

If required by the terms of engagement, the specialist contractor must provide, either in paper form or more commonly on computer files, information relevant to the installation that has been carried out.

This typically includes:

- Name of the manufacturer of the proprietary systems and/or components
- Type of partition and/or other systems, construction and finish, including working drawings, source for

obtaining replacements and any other relevant information

- 'As built' drawings if required
- Manufacturers' product information, including source of replacement material, and advice on maintenance, repair and disposal of materials for recycling at end of life
- Acoustic and fire test performance details
- Details of any special elements to the project
- Details of special characteristics, eg security glazing
- Details of access panels, type and catalogue numbers of appropriate keys
- Relevant COSHH data

Maintenance

- Advice on cleaning, including details of surface finishes, types and availability, and special polishes, detergents or cleaning agents that may be required
- Advice on removal and replacement of trims and skirtings
- Guidance on measures required to maintain fire integrity, particularly as they relate to seals and spread of flame of finishing materials
- Recommendations for attaching fixtures and fittings with details of any special requirements
- Advice on dismantling and re-assembling relocatable partitions and where appropriate, how to reseal the partitions at joints, perimeter junctions, abutments and surface penetrations to maintain integrity of performance

The O & M manual is left with the main contractor who in turn makes it available to the client.

References

Glossary of terms used in partitioning

The terms used to describe the many types of partitioning systems tend to vary from region to region across the country. Many benefits would accrue from a consistent use and a common understanding within the interiors industry. It is recommended therefore that the terms as given in British Standards and others as listed should be adopted as the preferred description.

The advent of an EOTA European Technical Approval Guideline (ETAG003) for partitions has produced a slight complication in the context of the preferred terminology within the UK. The guideline is entitled 'Internal partition kits for use as non-loadbearing walls'. British Standards define a wall as being 'loadbearing' and a partition as being 'non-loadbearing'.

The difficulties of gaining acceptance of British Standards' preferred terminology is exemplified by the term 'raised access floors', which is still the most widely used term within the industry, albeit the partition Standard BS 5234 prefers the term 'platform floors' and deprecates the use of the former.

Bi-Panel systems

Are made up of two single factory produced panels, usually in 1200mm or 1500mm module widths, hooked onto an upright stud section. Panels can be manufactured from steel faced plasterboard, veneered, painted and laminated MDF panels as well as glazed panels.

Cleanroom systems

Systems that are designed and installed to meet the high standards set out in BS 5295 (1989) Part 2 and ISO 14644-1. Whilst the partition is often only a small part of the total cleanroom specification, these close control environments, specifically required in sectors such as healthcare, pharmaceutical and biotechnology, require exacting standards.

Composite partition

There is no British Standard definition; the term is normally used to describe a 50mm frame and panel partition constructed from aluminium frames and cellular plasterboard or flaxcore panels. These partitions may include solid areas and glazed areas.

Deflection head

A special design feature at the head of a partition which allows its integrity to be maintained while allowing movement such as floor slab or beam deflection to take place.

Demountable partition

A partition system that cannot be taken down without damaging or destroying some or all of the components. ***Must not be confused with a Relocatable partition.***

Door **

Building component for closing and opening in a wall that allows access or passage and may admit light when closed. A left (right) hand door is one that opens with a rotating movement with the hinge position on the left (right) hand side when viewed from the opening side. When viewed on plan the door will move to open in a clockwise (anti-clockwise) direction.

Door assembly **

A complete assembly as installed, comprising door frame and one or more leaves, together with essential hardware supplied from separate sources. See also definition of door set.

Door frame **

Part of the door assembly in which the door leaf moves.

Door leaf **

An element which, when fitted with hinges in a door frame, forms part of a door assembly.

Door set **

A complete unit consisting of a door frame and door leaf or leaves, supplied with essential hardware as a product from a single source

Dry jointed glazed partitions

Methods of jointing single or double glazing, other than silicone. Aluminium, PVC or softer PVC joints can be used with the use of high bond tape.

Dry jointed plasterboard

A plasterboard system definition for the jointing of tapered edge plasterboard partitions. Can be either plaster skimmed or board joints taped and filled and screws at the board centre are filled and sanded smooth when set.

Fire door

A door which provides fire resistance. Normally a fire door assembly, single or double, including frame, leaf, ironmongery and seals which, in conjunction with the associated structure, has been tested to demonstrate compliance with appropriate British Standards.

Fixed partition

A partition which cannot be demounted without destroying, partially or totally, the integrity of the components.

Flaxboard core panel

Used in fixed and relocatable partition systems. Standard face finishes include mineral board and hardboard which can be overfaced with vinyl or decorative laminates. Usually available with square edges and can be machined to accept tongue jointing strips.

Flush door (leaf) **

A door which does not contain any raised or recessed features nor any openings except those which may be required to receive hardware.

Flush overpanel **

A fixed panel fitted within the head and jambs above the door leaf without a transom fitted and which is of a similar thickness and appearance to the door leaf.

Framed partition **

A partition consisting of a continuously supported plain frame with facings or infillings. It may take the form of a stud and sheet, frame and sheet or frame and panel partition.

Frame and panel partition **

A partition in which the composite panels are supported by the exposed framework. Typically, the panel edges are concealed by the framework. The panels, therefore, may be cut on site where necessary. The framework sections form openings for doors and glazing. Frame materials include extruded aluminium, steel and timber. Panels are usually proprietary products and include prefabricated gypsum wallboard panel, particle board and steel facing.

Frame and sheet partition **

A framed partition in which the framework is partially exposed. Sheet material supported by a framework and with expressed joints. The framework may provide cover to the sheet edge joints and the sections necessary to form door and glazing openings. Frame materials include extruded aluminium, timber and steel. Sheet materials include various types of plasterboard, plywood, chipboard, fibreboard and steel. Finishes can be either site or factory applied. Joint designs vary from simple butt joints to recessed joints with integral accessory supports.

A number of proprietary systems are based on this form of construction.

Frameless glass partitions

Generally 12mm or 15mm glass with polished edges, installed between head and floor tracks and jointed by silicone or the use of dry jointed sections

Glazed partition

A partition which includes transparent, translucent or obscure glass in its construction. It may be fully or partially glazed. The glazed areas may be double or single centre, or single off-set; these alternatives refer to the position of the glazing in relation to the thickness of the partition.

Hollow partition

A partition that has usable voids throughout most of its area (the converse of a solid partition).

Honeycombed core panel

A relatively lightweight non-loadbearing panel with a honeycombed core, usually faced with gypsum plasterboard. Intended for use in panel to panel mounting or for fixing into metal frames to form a fixed or relocatable partition. Also referred to as a dry partition panel or a prefabricated gypsum wallboard panel.

Hospital partition

Normally refers to various types of metal stud/plasterboard partitions with integral door sets which meet the Method of Building (MOB) specification for hospital partitions.

Hung panel partition system

A modular partition where the facing panels are 'hung' on the base frame instead of being faced fixed. Panels include plasterboard, melamine and veneer faced chipboard.

Independent wall lining

A lining (often using related partition components) which is erected independently from the external walling.

Jumbo metal stud separating wall

A metal stud/plasterboard non-loadbearing system using jumbo metal studs and channel sections which are clad on each side with layers of 19mm gypsum plank and 12.5 and 15mm thick plasterboards (the type, thickness and number of boards is dependent on the specified performance criteria). This system is used primarily for commercial and industrial applications where heights of up to 7m can be achieved.

Laminated partition

A fixed (non-relocatable) partition built on site from layers of 12.5mm plasterboard bonded with gypsum adhesive each side of a core of 19mm gypsum plank. The thickness and number of face boards can be varied to achieve various levels of performance. This type of partition is normally used in housing.

Masonry partition

A partition of brickwork or blockwork complete with any specified surface finishes such as drywall lining or plaster.

Note: If the construction has a loadbearing or retaining function it is a masonry wall.

Matching lining **

An independent vertical lining that is similar in construction and appearance to adjacent partitions.

Metal stud partition

A partition consisting of a metal stud/channel framework and lined both sides with sheet materials such as plasterboard. This is a form of stud and sheet partition and is sometimes described as a hollow plasterboard partition.

Metal stud separating wall

A twin frame metal stud/plasterboard partition which meets the separating wall requirements of national Building Regulations for multi-occupancy dwellings.

Monobloc partition **

A partition formed of prefabricated units capable of being moved without affecting adjacent units. The term relocatable monobloc is sometimes used. Most monobloc partitions consist of solid area, glazed and door panel modular units which can be demounted and readily relocated. The units are also often interchangeable. They may be made from metal or timber.

Note: Single unit elements which cannot be demounted from a partition run form a panel partition and should be so described.

Office pods

Informal office meeting spaces created as a self contained screen with fixed or sliding doors.

Operable walls**

A partition of separate sections that is capable of rearrangement by the occupants of the building. It usually consists of aluminium or steel framed panels in combination with straight run or multi-directional track systems. Finishes include vinyl wall covering, melamine, high pressure laminate, wallpaper, carpet and wood veneer.

Panel partition

A partition of prefabricated panels butted together in floor and head tracks without supporting framework. The range of panels includes glazed panels and door sets. Generally relocatable with the loss only of such items as perimeter fixings and sealing materials. The partition in its simplest form consists of sandwich panels fixed together with a tongue and groove joint.

Note: Some panel partitions are referred to incorrectly as monobloc partitions.

Partition

A partition is a non-loadbearing vertical construction.

Note: If the construction has a loadbearing or retaining function, it should be described as a wall.

Partition kit

A set of at least two separate components that need to be put together to be installed permanently in the works, ie to become an assembled system. (Definition given in a guidance paper concerning the Construction Products Directive 89/106/EC.)

Performance partition

This term is sometimes used to differentiate partitions which have good sound insulation and/or fire resistance performance and those which do not.

Any partition which does more than just create a visual barrier (which almost all do), is a performance partition. The functions of a performance partition may include sound insulation, fire resistance, reaction to fire and compliance with Building Regulations and other legislation. Impact resistance, wind loads, air pressure and other strength characteristics may also be performance features for specific areas of use. Generally, the use of the term performance partition is not encouraged.

Relocatable partition **

A relocatable or reusable partition system can be removed and relocated without substantial repair, using a minimum of 80% of the original components. It should be capable of reinstallation within a tolerance of plus or minus 10mm.

Screen

A partition that does not extend fully from floor to ceiling. Usually self-supporting and is easily movable. Screens provide a degree of protection or privacy. Normally available in straight and curved profiles with some having an adjustable height facility.

Security partitions

These take various forms. They involve constructions specifically designed to be resistant to ballistic and physical attack and small explosions such as those from letter bombs, etc. The term is also used for standard forms of relatively lightweight partitions incorporating additional membranes, such as sheet steel or expanded metal, which are designed to delay access to a protected space for a short period.

Where a high degree of security against penetration is required, masonry constructions are often used.

Shaftwall

A partition or lining consisting of multi-layers of gypsum plasterboard fixed to single or twin metal frames to give up to four hours fire resistance. The system is used to form fire protective enclosures to all forms of shafts including service cores to lift shafts.

Silicone butt jointed glazed partition

A partition of fixed panels of toughened or laminated glass mounted and restrained on only two edges (top and bottom) and jointed vertically with silicone. By concealing ceiling and floor channels, some proprietary systems have the ability to provide glazed partitions without visible frames.

Sliding and folding partition **

A partition of hinged leaves that can be folded away by moving them horizontally on a fixed track.

Solid area partition **

A partition without glazing.

Note: Not to be confused with a solid partition.

Solid partition **

A partition that has no usable void throughout most of its area. The term solid is sometimes used to describe masonry partitions.

Staggered metal stud partition

A partition based on a framework with alternate studs off-set within wide floor and ceiling tracks. This system is used where levels of sound insulation required are higher than those achieved with a single row of studs.

Steel stud partition

An alternative description for a metal stud partition.

Note: Not to be confused with steel framed systems utilising heavy gauge steel components for constructing loadbearing structural elements or complete buildings.

Storage wall

An integrated and modular storage partition providing both space division and volume storage. Most systems permit flexibility to change internal fittings to meet specific storage and filing requirements. Can be positioned as a partitioning divide between offices with doors facing both sides on adjoining bays or just the one side.

Stud and sheet partition **

Framed partition in which the studs and other ancillary members (noggings and sole plates, etc) are concealed by the facings. The stud materials include timber and steel and the sheet facing materials consist of various types of plasterboard, glass reinforced gypsum board, chipboard, fibreboard, etc. Finishes include taped and filled joints between sheets, and plaster.

Metal stud, timber stud and many proprietary systems are based on this form of partition construction.

Timber partition (or timber framed)

A traditional framed partition or one consisting of timber and metal sub-frames with the use of either timber profiles or applied veneered MDF sections to simulate a traditional timber appearance. Available in modular, solid area and glazed units. Note: Not to be confused with timber stud partition.

Timber stud partition

A partition consisting of a timber frame lined on each side with materials such as plasterboard. Sometimes described as a hollow stud partition (see also stud and sheet partition).

Note: Subject to timber sizes, some timber frame structures may be loadbearing; they should then be described as timber stud walls.

Tracked monobloc panel partition **

A movable monobloc panel partition supported and guided by a track mechanism (see also movable partition).

Tracked flexible partition **

A partition of variable length with flexible or hinged panel facings supported by a track mechanism (see also sliding and folding partition).

Vertical rising folding walls

These custom made systems with a variety of panel finishes, folds the partition into the ceiling void. Care needs to be taken in the early stages of the structural work to ensure that the systems weight loadings, which on the system are static, are fully considered.

Wall storage

Free-standing cupboard systems providing storage space, usually positioned against existing walls or partitions. Note: Not to be confused with storage walls.

Working wall

A partition or screen that combines with furniture to provide additional storage that improves acoustics and offers relocatable opportunities.

** British Standard definitions

Examples of different types of partitioning construction are shown below:

Stud and sheet partition

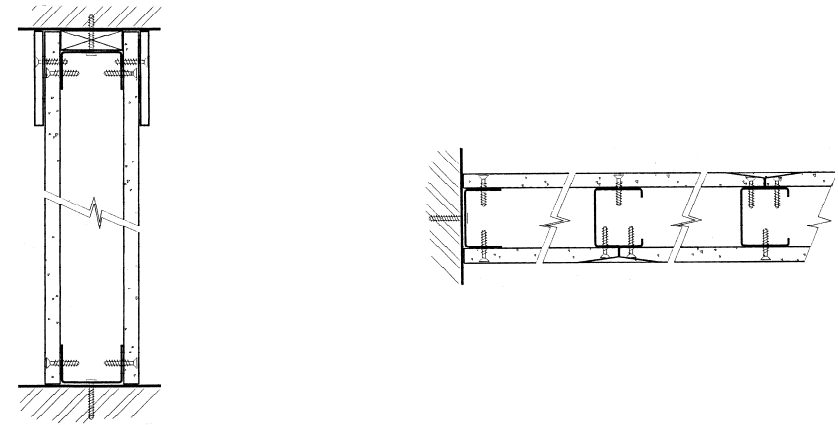

Partitions of sheet materials supported by and concealing studs and other ancillary members (noggings, floor battens, etc). Stud materials include timber and steel. Sheet materials include plasterboard, chipboard, plywood, fibreboard and steel. Finishes include single coat plaster, paint, etc.

Frame and sheet partition

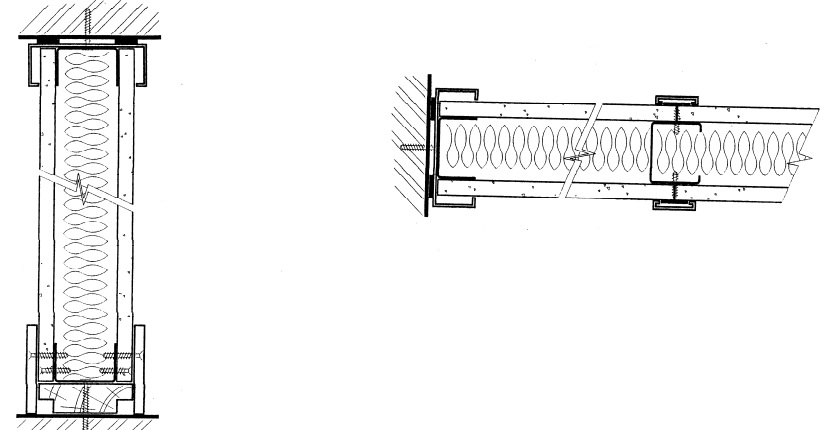

Partitions of sheet material supported by a framework and with expressed joints. The framework may provide cover to the sheet edge joints and the sections necessary to form door and glazing openings. Frame materials include extruded aluminium, timber and steel. Sheet materials include plasterboard, chipboard, plywood, fibreboard and steel. Finishes can be either site or factory applied. Joint designs vary from simple butt joints to recessed joints with integral accessory supports.

Frame and panel partition

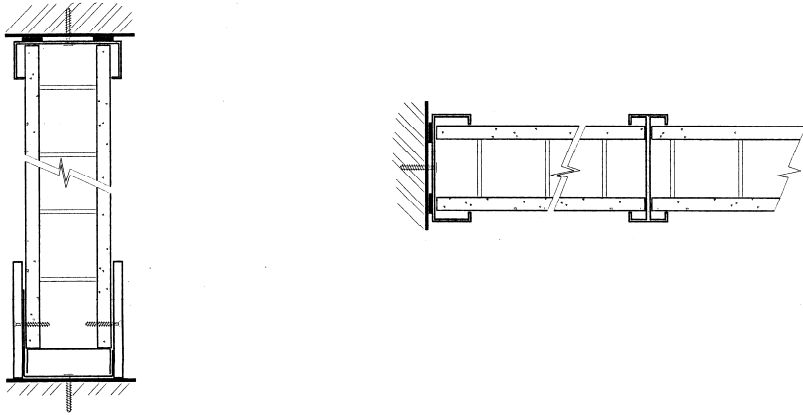

Partitions of composite panels supported by an exposed framework. Typically the panel edges are concealed by the framework. Therefore the panels may be cut to size on site where necessary. The framework sections form door and glazing openings. Frame materials include extruded aluminium, steel and timber. Panels are usually proprietary products and include prefabricated gypsum wallboard panels, steel facings, wood wool slabs and particle boards.

Panel partition

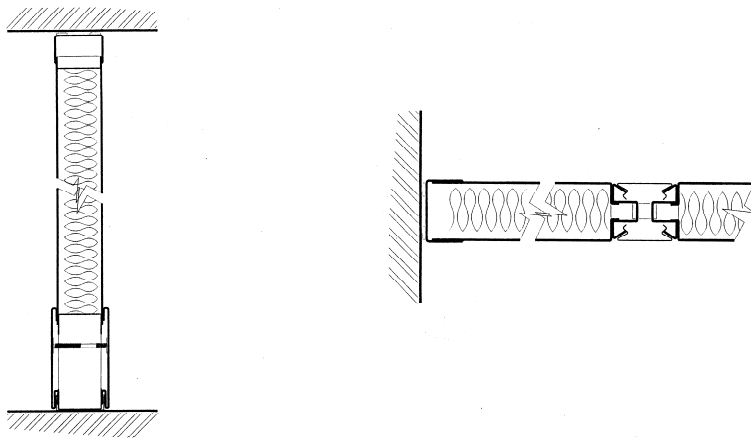

Partitions of prefabricated panels butted together in floor and head tracks without supporting framework. The range of panels includes glazed panels and door sets. Generally relocatable with the loss only of such items as some perimeter fixings and sealing materials. The simplest are sandwich panels fixed together with a tongue and groove joint. Proprietary panel materials include sheet steel facings with lightweight cores. In relocatable systems, channels can normally be fixed to ceilings and on floor finishes with limited damage.

Sliding and folding partition

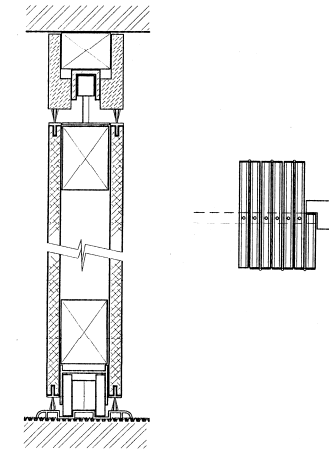

Solid panels are hinged together and run on rollers on top and/or bottom tracks. They range from lightweight non-acoustic timber to acoustically sealed systems. Track and storage configurations vary; adjacent storage space is necessary for flush stacking of panels.

Tracked monobloc partition (single panel, centre supported)

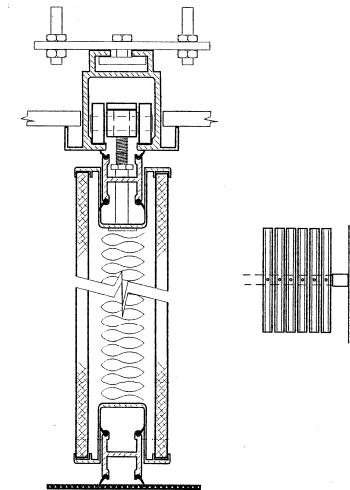

For ease of movement, track supported independent panels which lock into position with expanding seals. Panel construction follows closely the form of traditional monobloc fixed partitions. Panels may be top hung or floor supported or both. Electrically operated versions are available. There is a variety of stacking configurations. Recessed storage is necessary for flush stacking of panels.

Tracked flexible (concertina) partition

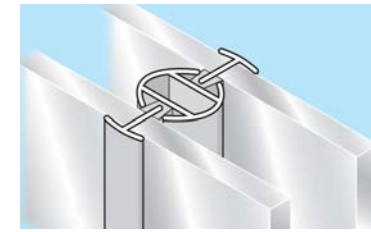
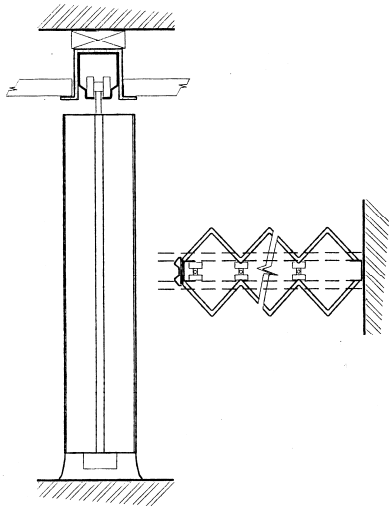

Variable length partitions with a concealed pantograph or similar supporting mechanism and flexible or hinged panel outer facings. Usually top hung with top and bottom 'sweep strips' incorporated to enhance acoustic performance.

Frameless glazing options

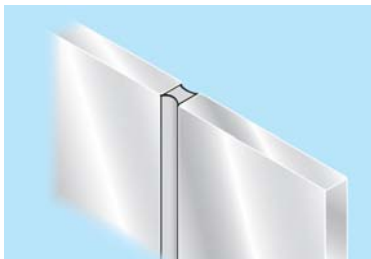

Vertical rising folding walls

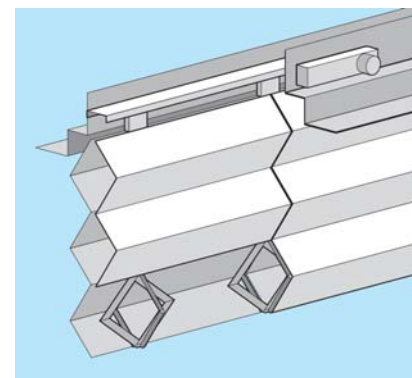

Other references

BS 476:	<i>Fire tests on building materials and structures</i>
Part 4: 1970 (1984)	<i>Non-combustibility test for materials</i>
Part 6: 1989	<i>Method of test for fire propagation for products</i>
Part 7: 1997	<i>Method for classification of the surface spread of flame of products</i>
Part 22: 1987	<i>Method for determination of the fire resistance of non-loadbearing elements of construction</i>
Part 23: 1987	<i>Methods for determination of the contribution of components to the fire resistance of a structure</i>
Part 31.1: 1983	<i>Methods for measuring smoke penetration through doorsets and shutter assemblies: Section 31.1: 1983 Method of measurement under ambient temperature conditions</i>
BS EN ISO 140:	<i>Acoustics. Measurement of sound insulation in buildings and of building elements</i>
BS EN ISO 140-3: 1995	<i>Laboratory measurement of airborne sound insulation of building elements</i>
BS EN ISO 10140-2 (2010) ditto	
BS EN ISO 140-4: 1998	<i>Field measurements of airborne sound insulation between rooms</i>
BS EN ISO 717:	<i>Acoustics: Rating of sound insulation in buildings and of building elements</i>
BS EN 717-1: 1997	<i>Airborne sound insulation</i>
BS EN 717-2: 1997	<i>Impact sound insulation</i>
BS EN 1364-1: 1999	<i>Fire resistance tests for non-loadbearing elements - walls</i>
BS EN 1364-2: 1999	<i>Fire resistance tests for non-loadbearing elements - ceilings</i>
BS EN 1365-4: 1999	<i>Fire resistance tests for loadbearing elements – columns</i>
BS EN 1366-1: 1999	<i>Fire resistance tests for service installations – ducts</i>
BS EN 1366-2: 1999	<i>Fire resistance tests for service installations – fire dampers</i>
BS EN 1991-1-1:2002	<i>Actions on structures. General actions. Densities, self-weight, imposed loads for buildings</i>
BS EN 12825: 2001	<i>Raised access floors</i>
BS EN 13964: 2004	<i>Suspended ceilings. Requirements and test methods</i>
BS 5234:	<i>Partitions (including matching linings)</i>
Part 1: 1992	<i>Code of practice for design and installation</i>
Part 2: 1992	<i>Specification for performance requirements for strength and robustness, including methods of test</i>
BS 5492: 1990	<i>Code of practice for internal plastering</i>
BS 6180: 1999	<i>Code of practice for protective barriers in and about buildings</i>
BS 6206: 1981 (1994)	<i>Specification for impact performance requirements for flat safety glass and safety plastics for use in buildings</i>
BS 6262: 1982	<i>Code of practice for glazing for buildings</i>
Part 4: 1994	<i>Code of practice for safety related to human impact</i>
BS 8000:	<i>Workmanship on building sites</i>
Part 5: 1990	<i>Code of practice for carpentry, joinery and general fixings</i>
Part 7: 1990	<i>Code of practice for glazing</i>
Part 8: 1994	<i>Code of practice for plasterboard partitions and drylinings</i>
Part 10: 1995	<i>Code of practice for plastering and rendering</i>

Part 11:	<i>Code of practice for wall and floor tiling</i>
Part 11.1: 1989 (1995)	<i>Ceramic tiles, terrazzo tiles and mosaics</i>
Part 11.2: 1990	<i>Natural stone tiles</i>
Part 12: 1989	<i>Code of practice for decorative wallcoverings and painting</i>
BS 8212: 1995	<i>Code of practice for drylining and partitioning using gypsum plasterboard</i>
BS 8214: 1990 (1992)	<i>Code of practice for fire door assemblies with non-metallic leaves</i>
BS 8300: 2001 (2009)	<i>Design of buildings and their approaches to meet the needs of disabled people. Code of practice</i>
BS EN ISO 9000 (formerly BS 5750)	<i>Quality management systems</i>
The Building Regulations (England and Wales)	
Approved Document B - <i>Fire Safety</i>	
Approved Document E - <i>Resistance to the passage of sound</i>	
Approved Document K - <i>Protection from falling, collision and impact</i>	
Approved Document L2A - <i>Conservation of fuel and power. New buildings other than dwellings</i>	
Approved Document L2B - <i>Conservation of fuel and power. Existing buildings other than dwellings</i>	
Approved Document M - <i>Access to and use of Buildings</i>	
Approved Document N - <i>Glazing – Safety in relation to impact, opening and cleaning</i>	
Regulation 7 - <i>Materials and workmanship</i>	
The Building (Scotland) Regulations	
The Building Regulations (Northern Ireland)	
The Health and Safety at Work Act	
Management of Health & Safety at Work Regulations	
Control of Substances Hazardous to Health Regulations (COSHH) 2002	
The Construction (Design and Management) Regulations (CDM) 2015	
Health & Safety Commission (HSC) Approved code of practice on management of health and safety at work	
Glass and Glazing Federation (GGF) Codes of practice on glass handling, storage, transport, and safety in the flat glass industry	
Property Services Agency (PSA) Method of Building Performance Specification - <i>MOB PF2 FS/SP: Platform Floors (Raised Access Floors)</i>	

FIS references

FIS Information Sheets
FIS Health and Safety Handbook
FIS Site Guide for Drylining
FIS Site Guide for Glazed Partitions
FIS Site Guide for Raised Access Flooring
FIS Site Guide for Suspended Ceilings
FIS Site Guide for Wallcoverings
FIS Website: www.thefis.org

The information and guidance contained in this site guide are provided in good faith in the interests of improving safety and good practice.

Whilst every care has been taken in its preparation, FIS cannot accept any responsibility for injuries to persons or damage to property, or for any violations of laws or regulations which may arise from the use of or reliance upon the information and guidance contained herein.

The information is for general guidance on good practice only. Each case must be treated with due regard to the location and circumstances prevailing.



FINISHES & INTERIORS SECTOR

SITE GUIDE PARTITIONING

Published by FIS
Copyright © FIS 2015

FIS gratefully acknowledges the considerable help given by all those FIS members involved in the preparation of this site guide.